

---

## **Accessories**

---

**80**    **Mounting brackets for Motorized Pulley and Idler**

---

**81**    **Tension rollers**

Tension Rollers, alternatives to standard Idler Pulleys



# Mounting brackets for Motorized Pulley and Idler

Product range																
Motorized pulley	Type	Material	D [mm]	F [mm]	I [mm]	K [mm]	S [mm]	T [mm]	V [mm]	W1 [mm]	X [mm]	X1 [mm]	Z [mm]	Z1 [mm]	Thread	Weight [kg]
80LS	KL 20	Aluminium	20	14	57	38	6,5	9	12	10	72	103	35	55	M6	0,14
113LS	KL 25	Aluminium	25	20	85	55	8,5	11	15	20	110	150	42	66	M6	0,51
138LS	KL 30-A	Aluminium	30	20	89	55	8,5	11	15	20	110	150	44,5	71	M6	0,54
138LS	KL 30-B	Cast iron with black powder coat	30	20	86	57	11	17	12	24	110	180	44,5	72	M8	1,4
165LS-320M	KL 41-HD	Steel with black powder coat	40	30	84	62	14	20	22	40	110	190	50	83	M8	2,1
165LS-320M	KL 41-S/S	Stainless steel	40	30	84	62	14	20	22	40	110	190	50	83	M8	1,9
320H	KL 42	Steel with black powder coat	50	40	121	90	18	30	25	50	150	250	70	110	M8	4,5

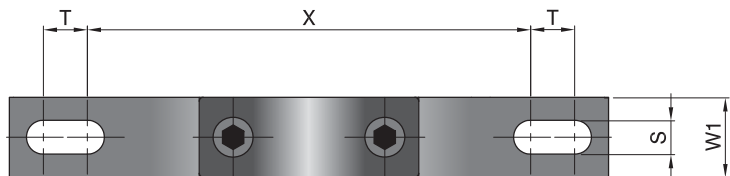
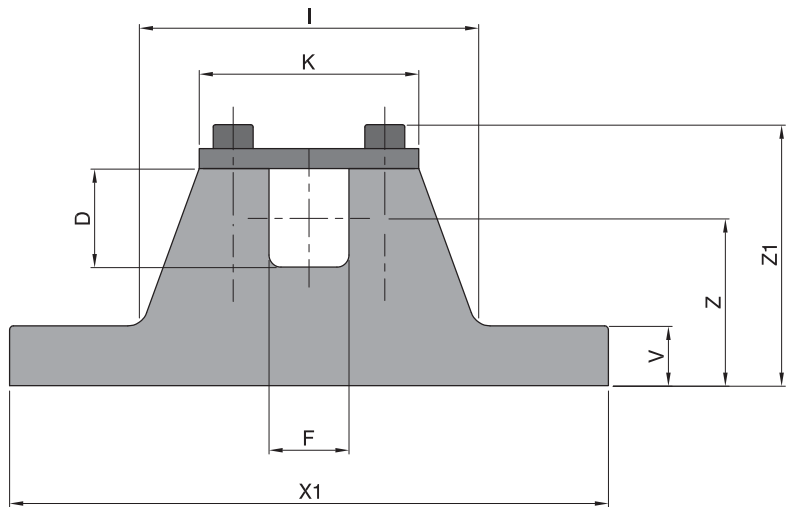

# Tension Rollers

## Alternatives to standard Idler Pulleys



### General characteristics

**APPLICATION:** For use on unit handling belt conveyors where Motorized Pulleys up to 165LS are used. Can be applied to most environments including wet, with specifications suitable for food handling.

**NOTE:** when required smaller roller diameters are available for limited space or weight applications.

**STANDARD EXECUTION:** steel or galvanized steel tube, steel shaft, shaft executions milled or drilled and threaded, labyrinth seals or external bearings 2RS.

Roller type:

**RSP:** With 2RS bearings seated in counter bored tube.

**MPS:** With 2RS bearings seated in counter bored tube and labyrinth seals with semi-hermetic outer trim in galvanized steel.

**117:** with polymer PA6 bearing seats and dual screen 2Z bearings lubricated for life.

**RTL:** with polymer PA6 bearing seats and labyrinth seals with semi-hermetic outer trim in galvanized steel.

**OPTIONS:** Electrolytic galvanized or stainless steel shaft, galvanized or stainless steel tube for food and / or wet applications.

Roller type	Ø D	s	d	e	Dimensions mm			Bearing	Shaft	Standard execution	
					Ch x g	M	C max			Tube	Sealings
<b>RSP/6H</b>	32 J	3	12	4		M8 x 15	500	6001 2RS	steel	galvanized steel	2RS Bearings
<b>MPS/3</b>	38 N	2,6	15	6,5	17 x 9		500	6202	steel	steel	labyrinth
<b>MPS/3</b>	38 N	2,6	15	6,5		M10 x 18	600	6202	steel	steel	
<b>117/15</b>	51 J	2	15	4	12 x 9		700	6202 2Z	steel	galvanized steel	Metal screen
<b>117/15</b>	51 J	2	15	4		M10 x 18	700	6202 2Z	steel	galvanized steel	2Z Bearings
<b>RTL/1</b>	60 J	2	15	4	17 x 9		600	6202	steel	galvanized steel	labyrinth
<b>RTL/1</b>	60 J	2	15	4		M10 x 18	700	6202	steel	galvanized steel	
<b>RSP/C9</b>	50 N	3	20	4	14 x 12		800	6204 2RS	steel	steel	2RS Bearings
<b>RSP/C9</b>	50 N	3	20	4		M12 x 20	800	6204 2RS	steel	steel	
<b>RSP/C9</b>	50 N	6	20	4	14 x 12		800	6204 2RS	steel	steel	
<b>RSP/C9</b>	50 N	6	20	4		M12 x 20	800	6204 2RS	steel	steel	
<b>RSP/3C</b>	60 N	6	25	4	18 x 12		1000	6205 2RS	steel	steel	
<b>RSP/3C</b>	60 N	6	25	4		M16 x 25	1000	6205 2RS	steel	steel	

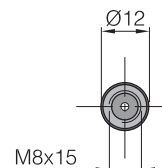
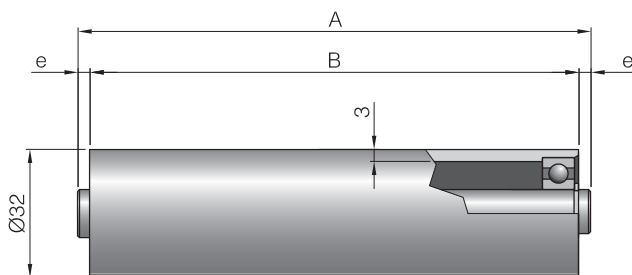

**RSP/6H**  
Drilled and threaded shaft execution



# Tension rollers

Alternatives to standard Idler Pulleys

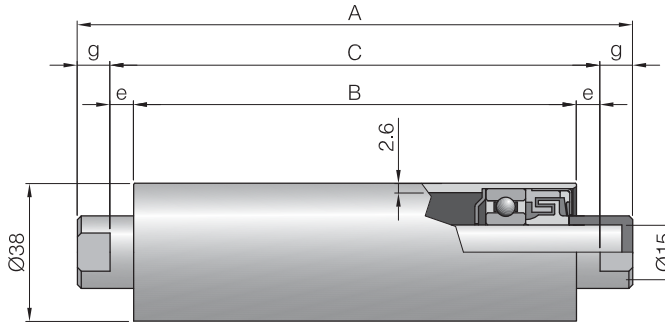

**MPS/3**  
shaft execution with key  
obtained with metal sleeve

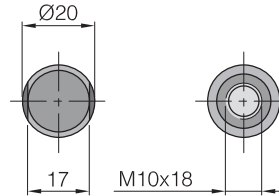

**MPS/3**  
drilled and threaded  
shaft execution

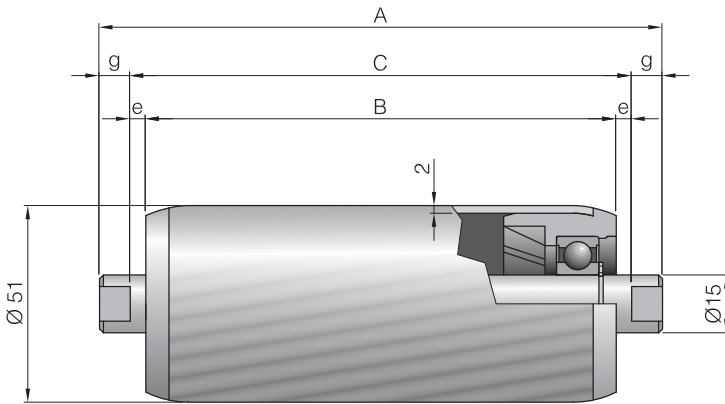

**117/15**  
flats shaft execution

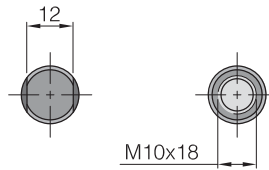

**117/15**  
drilled and threaded  
shaft execution

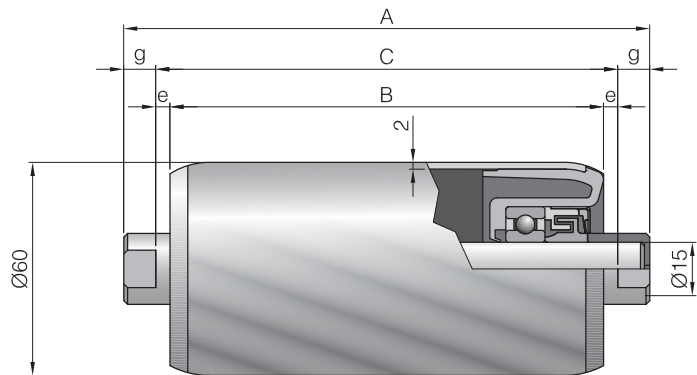

**RTL/1**  
shaft execution with key obtained  
with metal sleeve

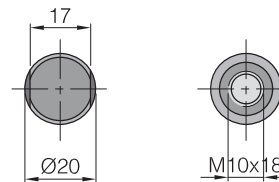

**RTL/1**  
drilled and threaded  
shaft execution

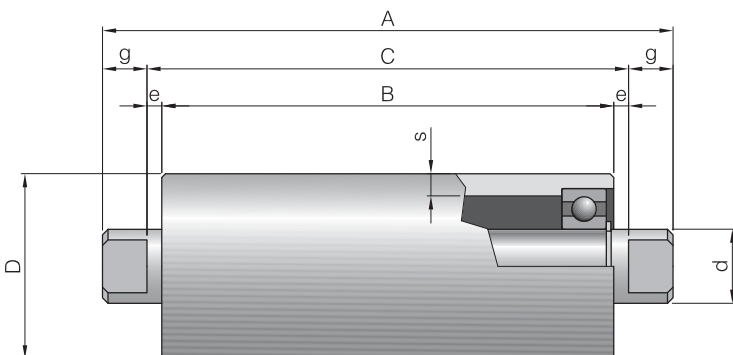

**RSP/C9, 3C**  
flats shaft execution

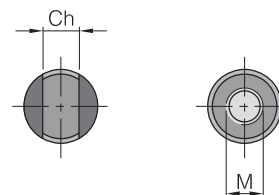

**RSP/C9, 3C**  
drilled and threaded  
shaft execution

# Tension rollers

Alternatives to standard Idler Pulleys



## Technical data and options on request

Roller type	Ø D	Max Speed		Max Capacity daN	Options	
		rev/min	m/s		Shaft	Tube
RSP/6H	32 J	600	1	100	J, I	N, I
MPS/3	38 N	600	1.2	110	J, I	J, I
MPS/3	38 N	600	1.2	150	J, I	J, I
117/15	51 J	600	1.3	120	J, I	N, I
117/15	51 J	600	1.3	150	J, I	N, I
RTL/1	60 J	500	1.6	120	J, I	N, I
RTL/1	60 J	500	1.6	160	J, I	N, I
RSP/C9	50 N	700	1.8	180	J, I	J, I
RSP/C9	50 N	700	1.8	180	J, I	J, I
RSP/C9	50 N	700	1.8	230	J, I	J
RSP/C9	50 N	700	1.8	230	J, I	J
RSP/3C	60 N	700	2.2	280	J, I	J
RSP/3C	60 N	700	2.2	280	J, I	J

Calculated flow rate at full load and maximum speed for a theoretical bearing life of 10,000 hours.

Contact Rulmeca for limit loads or other technical details.

The roller capacity must be greater than the belt tension T1 plus the carried load to avoid over deflection of the shaft and bearings.

### Key options

Tube:

N = black steel

J = electrolytically galvanized

I = stainless steel AISI 304

Shaft:

J= electrolytically galvanized

I = stainless steel AISI 304

For higher flow rates and protection ratings up to IP67, please use Idler pulleys of the same series and diameters of Motorized Pulleys, presented in the relative drawings and tables. For special rollers contact Rulmeca.



## **Planning Section**

---

<b>86</b>	<b>Environmental conditions</b>
<b>89</b>	<b>Different power supply</b>
<b>90</b>	<b>Industrial solutions</b>
<b>91</b>	<b>Power calculation and selection of the Motorized Pulley for package transportation</b>
<b>93</b>	<b>Oil types and contents</b>
<b>95</b>	<b>Connection diagrams</b>

## Hygienic conditions

For food processing and other applications where hygiene is paramount we recommend the following materials, connectors and accessories:

- Stainless steel Shell,
- Stainless steel Shaft,
- Stainless steel End housing - TS8N/10N version.,
- IP66 Sealing with NBR or FPM with stainless steel labyrinth motorized pulleys
- Hot vulcanized Lagging, FDA approved, white nitrile rubber NBR or in polyurethane PU
- Oil, food-grade, synthetic
- Stainless steel Terminal box
- Straight or elbow connectors in stainless steel
- Diamond patterned lagging is not suitable for food processing as it can be difficult to clean and leave traces of bacteria

## Conveyor frame

According to EHEDG design rules, it is highly recommended to incorporate rust-free open conveyor frames to facilitate easy cleaning, wash down and disinfection of the conveyor, motorized pulley and belt. The rubber material shall be USDA/FDA and EC1935/2004 compliant.

## Wet and wash down applications

Wet and wash-down subject applications require rust-free or stainless steel materials for the motorized pulley shell and sealing system.

The following materials and accessories are available:

- Stainless steel or mild steel Shell with hot vulcanised lagging
- Stainless steel Shaft,
- End housing for saltwater resistant (80 LS-138LS) powder coating (165LS-320H) or with stainless steel shell (80LS-320M)- TS8N/10N version
- End housings for S-series, aluminium with stainless steel cover
- IP66 seal, nitrile rubber NBR or FPM, with stainless steel labyrinth
- Lagging, all types possible
- Diamond patterned lagging can be used for non-food wet applications
- Cable connectors, all types possible
- Max. 50 bar at a distance of 0.3 m
- Max. 60°C water temperature for nitrilic rubber NBR regreasable sealing
- Max. 80°C water temperature for nitrilic rubber NBR or FPM sealing



## Dry and dusty applications

All Rulmeca Motorized Pulleys regardless of specification or material, are sealed to IP66 protection rating. For applications in hazardous areas requiring intrinsically safe or explosion proof motors, please contact Rulmeca.

## High temperature

With Rulmeca Motorized Pulleys, the cooling is due to the contact of the shell with the conveyor belt. It is essential that every motorized pulley, has an adequate temperature difference between the internal motor and its ambient operating temperature.

All Motorized Pulleys in the catalogue are designed and tested, without lagging and with a belt for use in a maximum ambient temperature of +40 °C.

- The maximum ambient temperature for standard Rulmeca Motorised Pulleys is 40° C according to EN 60034
- Every execution is possible, stainless steel versions allow a lower heat dissipation
- Before installing, make sure that the type of oil, declared on the label of the motorized pulley, ensures a temperature range compatible with the temperature of the applications environment.
- The rubber coating for modular belts can cause overheating of the Motorized Pulley, therefore only use recommended specifications
- De-rated motors or standard motors with frequency converters, properly configured for reducing running temperatures (Reduced power and inrush current)
- The rubber lagging to increase the friction with the belts can cause overheating; comply with the limits allowed for the lagging and always connect the motors internal thermal protection.
- For motorized pulleys with motors 6, 8, 12 poles and lagging thicker than 8 mm, use standard motors with frequency converters or de-rated Motorized Pulleys
- For applications with ambient temperatures above +40 ° C, please contact Rulmeca



## Environmental conditions

### Low temperature

When a Motorized Pulley is operated in low temperatures (less than +5 °C), the viscosity of the oil and temperature of the motor when it is not running should be considered. Consider also that condensation inside the motorized pulley and terminal box may occur with varying wide ranging temperatures.

We recommend the use of the following materials, cables and accessories:

- Mild steel with hot vulcanised lagging or stainless steel Shell
- Stainless steel Shaft,
- End housing in salt water resistant aluminium or solid stainless steel-TS version
- Sealing stainless steel with labyrinth
- Optional special oils for low temperatures
- Use special low temperature seals in temperatures below -25 °C
- System Activation of pre-heating, to prevent condensation
- Lagging, all types possible
- Very low temperatures reduce the effectiveness of the rubber to increase friction
- Cable connections: possible all kinds
- Use of anti rust materials

### Anti Condensation heating

In ambient temperatures below +1 °C, consider heating the motor windings to keep the oil viscosity, seals and internal parts at a constant temperature.

If the motor current is switched off for some time and the ambient temperature is very low, then the motor oil becomes viscous. In these situations opt for the use of condensation heating systems, also in order to avoid the formation of ice crystals within the oil seals that would result in a premature damage.

Please refer to Rulmeca.

### Altitude higher than 1000 m

The operation of a motorized pulley at an altitude above 1000 m above sea level may result in a loss of power and overheating due to low atmospheric pressure and the lower density of the air, which cools the motor. The altitude of the final application should be taken into consideration when calculating the required power. For more information please contact Rulmeca.

## Different power supply



### **Connecting 3-phase motors to a single phase supply**

3-phase motors combined with a frequency converter can be connected to a single phase supply providing that the supply voltage is the same as that of the motor. 3-phase motors generally have a much higher efficiency than single phase motors.



## Industrial solutions

Rulmecca offers a wide range of industrial solutions for different applications and market sectors. This chapter will only give an overview of some the most important areas covered.

### General logistics

Conveying in internal logistics, warehousing and storage handling covers a wide spectrum of applications, such as electronics, chemicals, food, automotive and general manufacturing. All Motorized Pulleys in this catalogue are suitable for general logistics applications.

### Food application

Rulmecca motorized pulleys are ultra-hygienic and easy to clean. All motorized pulleys for food processing comply with EC 1935-2004 and FDA.

### Airport logistics

Airport applications, such as check-in conveyors, X-Ray machines and scanning equipment, require low noise and frequent start / stops. Most applications use friction drive belts made of PU, PVC or rubber.

Suitable motorized pulleys:

- Standard motorized pulleys with 4 or 6 poles offer low noise levels that are typically below 56 dB.
- Motorized pulleys with Lower noise levels can be supplied on request
- Baggage handling systems (138LS-320M)
- X-Ray and check-in conveyors (113LS-138LS)
- Lagging for standard belts to increase friction
- Backstops for inclined conveyors
- Brakes for holding the belt stationary
- Halogen-free cables available

# Power calculation and selection of the Motorized Pulley for unit handling

## Calculation of the tangential force

- $F$  = Tangential Force [N].  $F = F_0 + F_1 + F_2 + F_3$   
 The tangential forces for motorized pulleys are given in the tables of the range of standard products
- $P_n$  = Belt weight per linear metre [kg/m]
- $P_{pr}$  = Weight of rotating parts of the belt conveyor per metre length (carrying and return section) [kg/m]
- $P_{m1}$  = Weight in Kg of the conveyed product on the load section, for each metre of length of the belt conveyor [kg/m]
- $P_{m2}$  = Weight in Kg of the conveyed product on the return section, for each metre of length of the belt conveyor [kg/m]
- $C_1$  = Coefficient of friction between product and belt carrying side
- $C_2$  = Coefficient of friction between belt carrying side and slider bed
- $C_3$  = Coefficient of friction between return belt and product
- $C_4$  = Coefficient of friction between return belt side and slider bed
- $L$  = Length of the conveyor in metres [m]
- $H$  = Height difference in conveyor [m]
- $F_0-F_3$  = Force [N]

Coefficient of friction			
$C_2$ o $C_4$	Belt PE	Belt PP	Belt POM
Slide bed	0.30	0.15	0.10
Steel or stainless steel scroll plan slide bed	0.15	0.25	0.20

$C_1$ o $C_3$	Belt PE	Belt PP	Belt POM
Steel product	0.15	0.30	0.20
Glass product	0.15	0.15	0.15
Plastic product	0.10	0.15	0.15

## Calculation of the tangential force

Conveying system	Force without load	Force to convey materials horizontally	Force to convey materials on incline	Accumulation
 Roller bed conveyor	$F_0 = 0.4 \cdot L \cdot (2P_n + P_{pr})$	$F_1 = 0.4 \cdot L \cdot P_{m1}$	$F_2 = 10 \cdot H \cdot P_{m1}$	$F_3 = 10 \cdot L \cdot P_{m1} \cdot C_1$
 Slide bed conveyor	$F_0 = 11 \cdot L \cdot P_n \cdot C_2$	$F_1 = 11 \cdot L \cdot P_{m1} \cdot C_2$	$F_2 = 10 \cdot H \cdot P_{m1}$	$F_3 = 10 \cdot L \cdot P_{m1} \cdot C_1$
 Double slide bed conveyor	$F_0 = 10 \cdot L \cdot P_n \cdot (C_2 + C_4)$	$F_1 = 10 \cdot L \cdot (P_{m1} \cdot C_2 + P_{m2} \cdot C_4)$	$F_2 = 10 \cdot H \cdot (P_{m1} - P_{m2})$	$F_3 = 10 \cdot L \cdot (P_{m1} \cdot C_1 + P_{m2} \cdot C_3)$

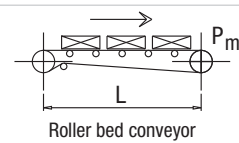
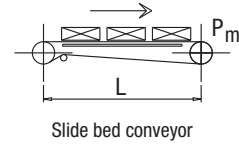
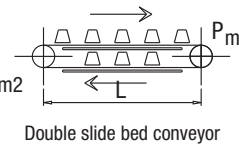

# Required data for power calculation

## Section A - Order detail

Motorized Pulley (TM)	Q.ty	Ø [mm]	Type	[kW]	Phase	Voltage [V]	[Hz]	[m/s]	RL [mm]	EL [mm]	AGL [mm]
Idler Pulley (UT)	Q.ty	Ø [mm]	Type						RL [mm]	EL [mm]	AGL [mm]
<b>TM</b>	<b>UT</b>	Note: please mark the required options with a cross					New EDP code:			Additional comments:	
		Terminal box stainless steel:				Terminal box aluminium:					
		Elbow connector stainless steel:				Elbow connector polyamide:					
		Straight connector stainless steel:				Straight connector brass:					
		Cable length [m]:				Cable type (screened/halogen free):					
		Insulation class:									
		Special certification:				CSA:		FDA:			
		Backstop:				Motor turning direction (at connection side):					
		Elektromagn. brake:				AC voltage to rectifier [V]:					
		Ø 80 - 220 RLmin + 50 mm				Fail safe unit:		Starts/Stops:			
		Special thermal controller:				(PTC):					
		Encoder option:		SKF:		RLS:		Special:			
		VFD-operation:				delivered with VFD:					
		Reversible operation:				Starts/Stops per hour:					
		Stainless steel option:									
		TS8N/TS10N:				TS7N/TS9N (with regreasable labyrinths):					
		Oil:		FDA:		Synthetic:					
		Special environmental condition - kind of aggressivity:									
		Temperature of material to be conveyed if higher than 70°C:									
		Ambient temperature if higher than 40°C or lower than - 25°C:									
		Special mounting vertical:				or with an angle of:		degrees			
		Cylindric shell:				Diameter (if special) [mm]:					
		Additional motor data plate required:									
		Special shell: (customer drawing has to be included)									
		Special shaft design: (customer drawing has to be included)				H [mm]:					
		F (key width) [mm]:		D [mm]:		K or C (flat length) [mm]:					
		Special end housings: (customer drawing has to be included)									
		Low noise requirements [dBA]:		dBA							
		Rubber lagging black/white/blue:				hot/cold vulcan.		Special:			
		Thickness of the lagging [mm]:									
		Special groove measurements: (customer drawing has to be included)									
		Groove type:		Groove dimens. [mm]:		Top:		Bottom:		Depth:	

## Section B - Necessary details for power calculation

Type of conveyor:	Slider bed:	Roller bed:	Special:	Inclining/Declining:
Conveyor length [m]:		Load [kg/m]:	Belt width [mm]:	Belt material:
Belt type:		Belt thickness [mm]:	Belt manufacturer:	
Additional comments:				
Environmental conditions:				
Accessories:				

## Oil types and contents



Motorized Pulley Oil type	IEC34 Insulation Class	Ambient Temp.	ISO 3498 DIN51519	DIN 51517	Castrol	BP	ESSO Mobil	Shell	Texaco	Fuchs
<b>80LS Standard mineral</b>	F	-5°C +40°C	CC ISOVG 68	CLP ISOVG 68	ALPHA SP 68	ENERGOL GR-XP 68	MOBILGEAR 600 XP 68	OMALA 68	MEROPA 68	
<b>80LS Synthetic option</b>	F & H	-25°C +40°C	CC ISOVG 68	CLP ISOVG 68	ALPHA SYN T 68		SHC 626 68			
<b>80LS Synthetic food grade</b>	F & H	-40°C +40°C	CC ISOVG 68	CLP ISOVG 68						CASSIDA FLUID HFS 68
<b>113LS Standard mineral</b>	F	-5°C +40°C	CC ISOVG 150	CLP ISOVG 150	ALPHA SP 150	ENERGOL GR-XP 150	MOBILGEAR 600 XP 150	OMALA 150	MEROPA 150	
<b>113LS Synthetic option</b>	F & H	-25°C +40°C	CC ISOVG 150	CLP ISOVG 150	ALPHA SYN T 150		SHC 629 150			
<b>113LS Synthetic food grade</b>	F & H	-30°C +40°C	CC ISOVG 150	CLP ISOVG 150						CASSIDA GL150
<b>138LS - 320H Standard mineral</b>	F	-5°C +40°C	CC ISOVG 150	CLP ISOVG 150	ALPHA SP 150	ENERGOL GR-XP 150	MOBILGEAR 600 XP 150	OMALA 150	MEROPA 150	
<b>138LS - 320H Synthetic option</b>	F & H	-25°C +40°C	CC ISOVG 220	CLP ISOVG 220	ALPHA SYN T 220		SHC 630 220			
<b>138LS - 320H Synthetic food grade</b>	F & H	-30°C +40°C	CC ISOVG 220	CLP ISOVG 220						CASSIDA GL220

### Oil contents in litres for vertical mounting regardless of drum width

	Litres	Special construction
<b>Ø 80</b>	0.2	} Electrical connection to be located at the top
<b>Ø 113</b>	0.6	
<b>Ø 138</b>	1,4	
<b>Ø 165</b>	3.0	
<b>Ø 220</b>	10	
<b>Ø 320</b>	25	

**Note:** The given oil contents are valid for standard unlagged drum motors only.  
For special options the oil quantity can deviate. Therefore always use the given oil quantity shown on the data plate.



## Oil types and contents

RL	80LS	113LS	138LS	165LS	220M & 220H		320L 0.75 - 4.0kW	320M & 320H		
					0.37 - 0.55kW 1.1-1.5kW	0.75kW 2.2-5.5kW		0.75 - 3.0kW	4.0 - 5.5kW	7.5 - 11.0kW
200	0,10									
250	0,14	0,32								
300	0,18	0,43	0,7							
350	0,22	0,54	0,9	1,2						
400	0,26	0,65	1,1	1,4	3,00		6,5			
450	0,30	0,76	1,3	1,6	3,50	4,00	7,0			
500	0,34	0,87	1,5	1,8	4,00	5,00	7,5	3,50	8,0	10,0
550	0,38	0,98	1,8	2,0	4,25	5,25	8,0	3,75	8,5	10,5
600	0,42	1,09	2,0	2,3	4,50	5,50	9,0	4,00	9,0	11,0
650	0,46	1,20	2,2	2,5	4,75	5,75	9,5	4,25	9,5	12,0
700	0,50	1,31	2,4	2,7	5,00	6,00	10,0	4,50	10,0	13,0
750	0,54	1,42	2,6	2,9	5,25	6,25	10,5	5,00	10,5	13,5
800	0,58	1,53	2,8	3,1	5,50	6,50	11,0	5,50	11,0	14,0
850	0,62	1,64	3,0	3,3	5,75	6,75	11,5	5,75	11,5	15,0
900	0,66	1,75	3,2	3,5	6,00	7,00	12,5	6,00	12,0	16,0
950	0,70	1,86	3,4	3,7	6,25	7,25	13,0	6,25	13,0	17,0
1000	0,74	1,97	3,7	3,9	6,50	7,50	14,0	6,50	14,0	18,0
1050		2,08	3,8	4,1	6,75	7,75	14,5	6,75	14,5	18,5
1100		2,19	4,0	4,4	7,00	8,00	15,0	7,00	15,0	19,0
1150		2,30	4,2	4,6	7,25	8,25	16,5	7,50	16,5	20,5
1200		2,41	4,4	4,8	7,50	8,50	18,0	8,00	18,0	23,0
1250			4,6	5,0	7,75	8,75	19,0	8,50	19,0	24,0
1300			4,8	5,2	8,00	9,00	20,0	9,00	20,0	25,0
1350			5,0	5,4	8,25	9,25	21,0	9,50	21,0	26,5
1400			5,1	5,6	8,50	9,50	22,0	10,00	22,0	28,0
1450			5,3	5,8	8,75	9,75	23,0	10,50	23,0	29,0
1500			4,8	6,0	9,00	10,00	24,0	11,00	24,0	30,0
1550			5,0	5,8	9,25	10,25	25,0	12,00	25,0	31,5
1600			5,1	6,0	9,50	10,50	26,0	13,00	26,0	33,0
1650			5,3	6,2	10,00	11,00	27,0	14,00	27,0	34,0
1700			5,5	6,4	11,50	11,50	28,0	15,00	28,0	35,0
1750			5,6	6,6	12,00	12,00	29,0	16,00	29,0	36,0
1800			5,8	6,8	13,00	13,00	30,0	17,00	30,0	37,0
1850			5,9	7,0	13,50	13,50	30,5	18,00	30,5	38,5
1900				7,1	14,00	14,00	31,0	19,00	31,0	40,0
1950				7,3	15,50	14,50	31,5	20,00	31,5	40,5
2000				7,5	15,00	15,00	32,0	21,00	32,0	41,0



# 80LP-113LP Connection diagrams



## Connection diagrams for Motorized Pulley cable connection 80LP - 113LP

Colors or lead numbers for standard turning direction clockwise.  
(lead numbers for screened cable)

TP - Thermal protector T1 & T2

### Color code

- gn - green
- ye - yellow
- bu - blue
- bn - brown
- vt - violette
- bk - black
- wh - white
- rd - red
- gy - grey

3-Ph motor  
dual voltage  
with TP

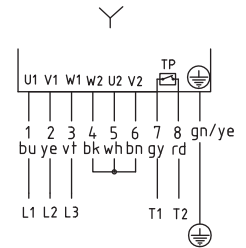
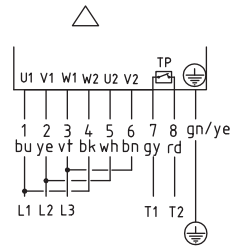

1-Ph motor  
with TP

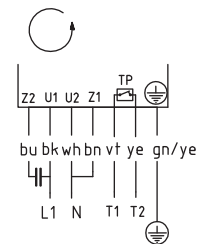
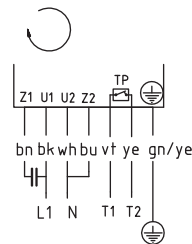

3-Ph motor  
single voltage  
with TP &  
6 leads

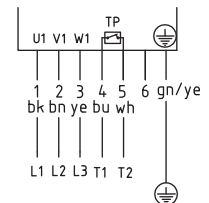

Lead 6 not used

## Connection diagrams for Motorized Pulley cable connection 80LS - 165LS ELB - only single voltage

Lead numbers for standard turning direction clockwise.

TP - Thermal protector T1 & T2

ELB - Electromagnetic brake B1 & B2

### Color code

gn - green  
ye - yellow  
bu - blue  
bn - brown

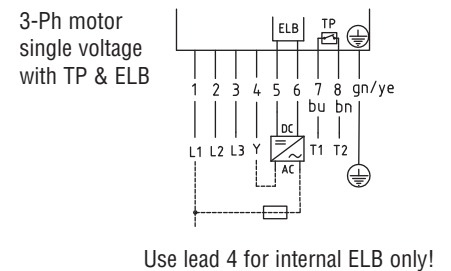
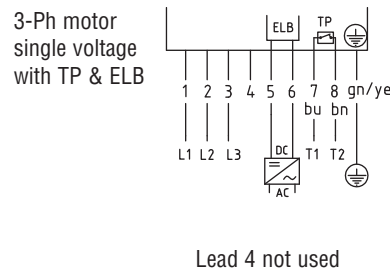
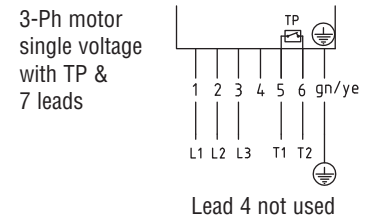
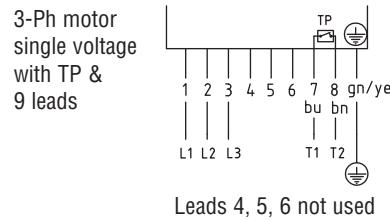
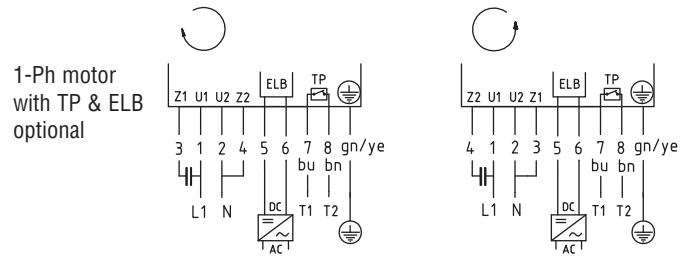
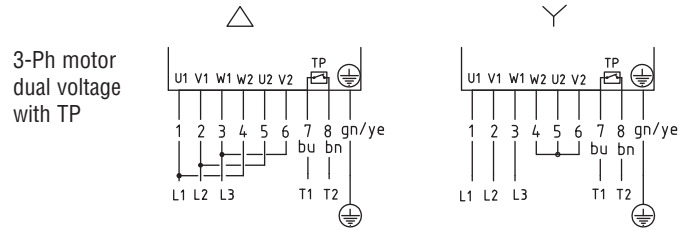

# 113LS Connection diagrams



## Connection diagrams for Motorized Pulley Terminal box with WAGO clamp 113LS (ELB only single voltage)

Characters in brackets for 2 stage gearbox  
turning direction clockwise.

TP - Thermal protector T1 & T2

ELB - Electromagnetic brake B1 & B2

### Color code

- RD - Red
- BN - Brown
- BK - Black
- GY - Grey
- BU - Blue
- VT - Violet
- WH - White

### Assembly instruction

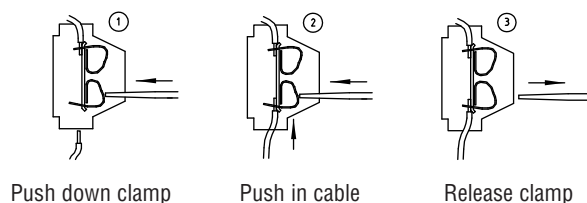

3-Ph motor  
dual voltage  
with TP

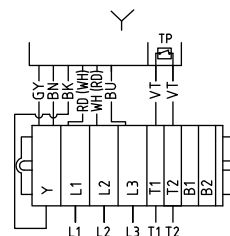
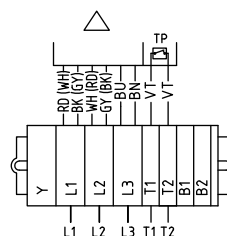

3-Ph motor  
single voltage  
with TP

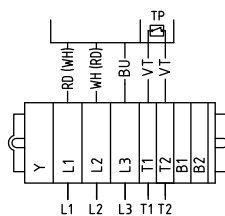

3-Ph motor  
single voltage  
with TP & ELB

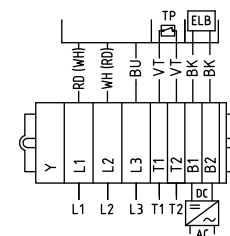

1-Ph motor  
with TP

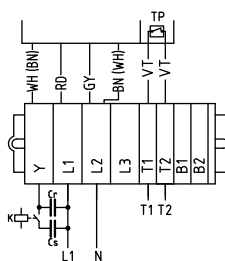

Cr - Run capacitor  
Cs - Start capacitor

1-Ph motor  
with TP & ELB

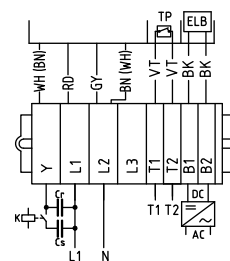

Cr - Run capacitor  
Cs - Start capacitor

# 138LS - 400L Connection diagrams

## Connection diagrams for Motorized Pulley Terminal box with WAGO clamp 138LS - 400L (138LS - ELB only single voltage)

Characters in brackets for 2 stage gearbox turning direction clockwise.

TP - Thermal protector T1 & T2

ELB - Electromagnetic brake B1 & B2

### Color code

RD - Red  
YE - Yellow  
BK - Black  
GY - Grey  
BU - Blue  
GN - Green  
WH - White  
BN - Brown

### Assembly instruction

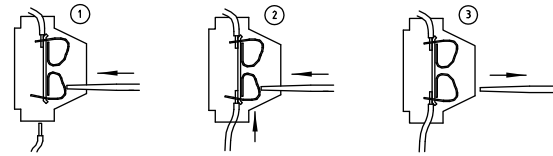

Push down clamp

Push in cable

Release clamp

3-Ph motor dual voltage with TP

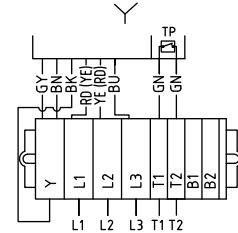
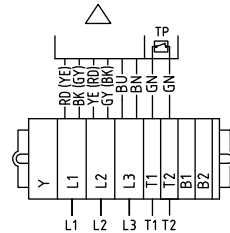

3-Ph motor dual voltage with TP & ELB

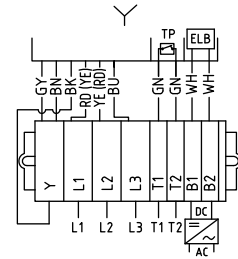
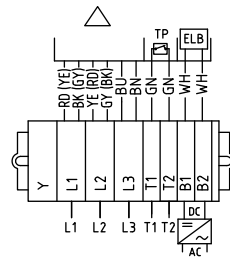

3-Ph motor single voltage with TP

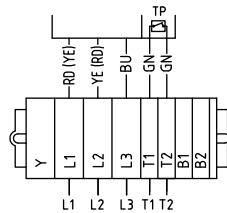

3-Ph motor single voltage with TP & ELB

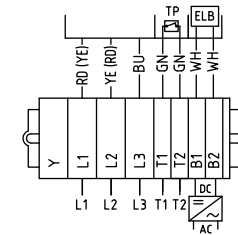

1-Ph motor with TP

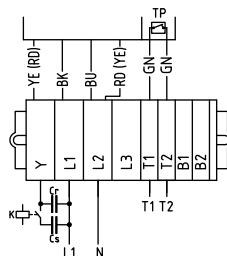

1-Ph motor with TP & ELB

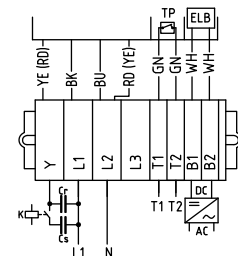

Cr - Run capacitor  
Cs - Start capacitor

Cr - Run capacitor  
Cs - Start capacitor

# 220M - 400L Connection diagrams



## Connection diagrams for Motorized Pulley Cable connection 220M - 400L

Lead numbers for turning direction clockwise.

TP - Thermal protector T1 & T2

ELB - Electromagnetic brake

### Color code

GN - Green

YE - Yellow

3-Ph motor  
dual voltage  
with TP

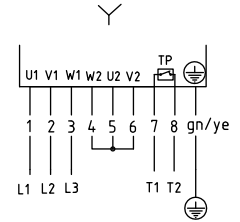
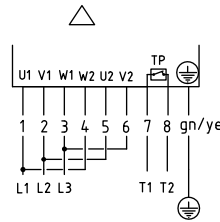

3-Ph motor  
dual voltage  
with TP & ELB

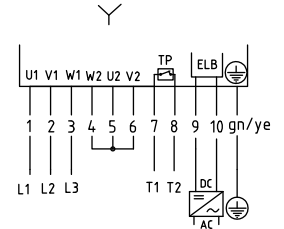
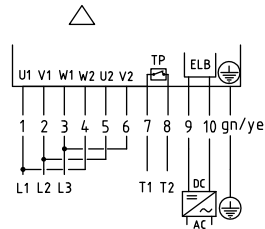

1-Ph motor  
with TP & ELB  
optional

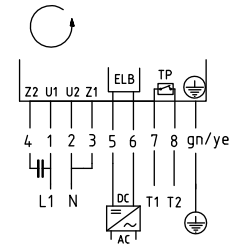
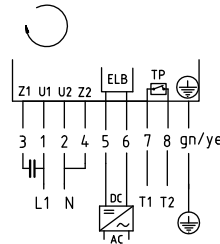

3-Ph motor  
single voltage  
with TP & ELB

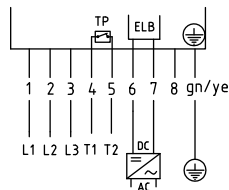

Lead 8 not used

3-Ph motor  
single voltage  
with TP

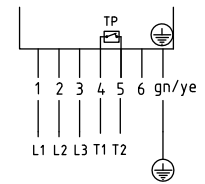

Lead 6 not used

# External Connection Diagrams for Motorized Pulleys 5.5 kW - 7.5 kW

## Terminal Box 5.5 kW - 7.5 kW

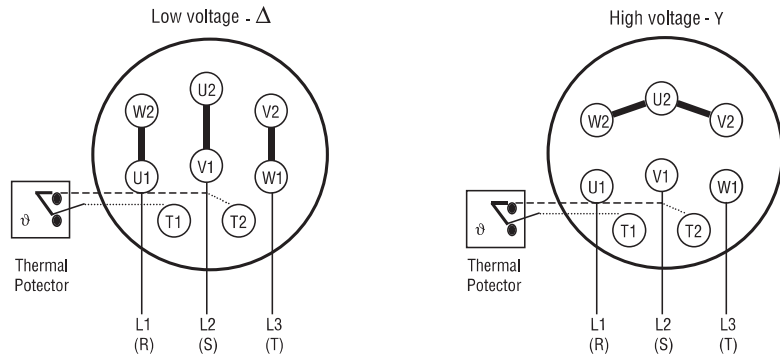

## Electromagnetic Brake Configuration

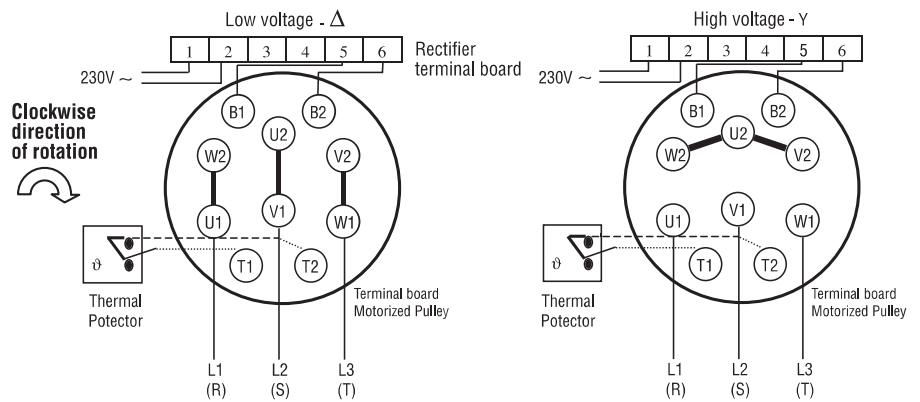

## 3-phase single voltage 5.5 kW - 7.5 kW

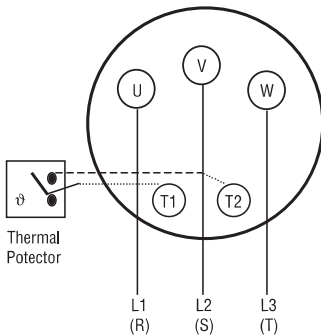

## USA - Configuration

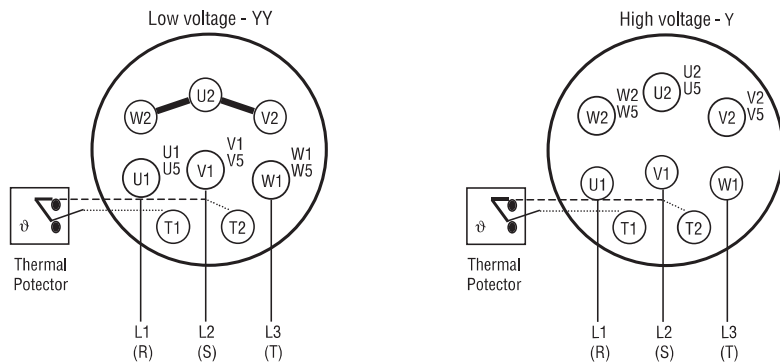

## The Rulmeca product range

The Rulmeca product range for the Unit Handling sector comes complete with:

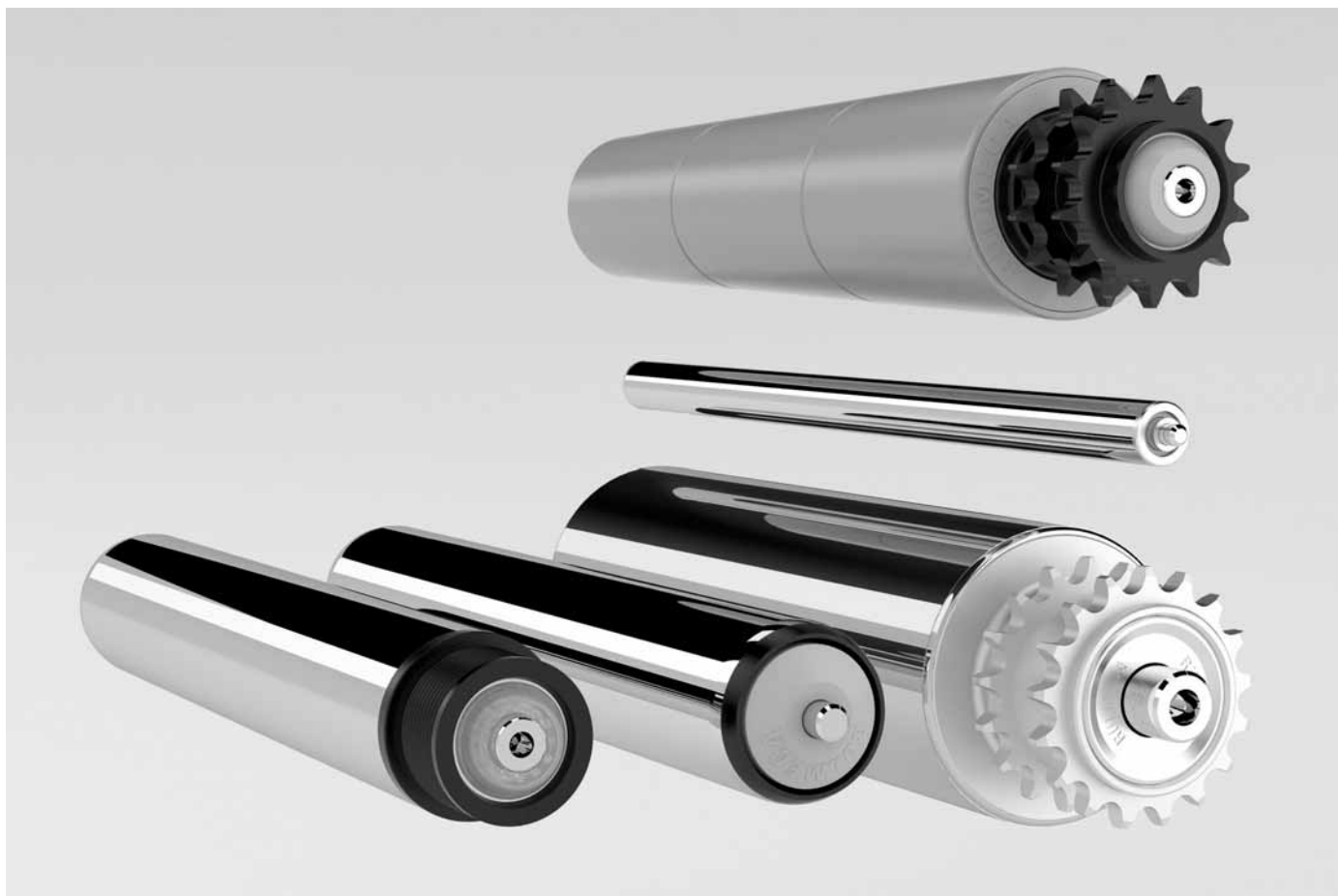

**Rollers and Components for Unit Handling and Industrial Applications Catalogue**



## The Rulmeca product range

The Rulmeca product range for the Unit Handling sector comes complete with:



**Solutions for Dynamic Warehouses Catalogue**





